



JinLong Machinery

VibratorMotor.com

KOTL

Home | Product Info | About us | Factory tour | ISO Certifications | RoHS Info | Sample Request | Contact us | Email us

Part No. Z6SCAA0061141 (Old Part Number : Z6S00A010F)

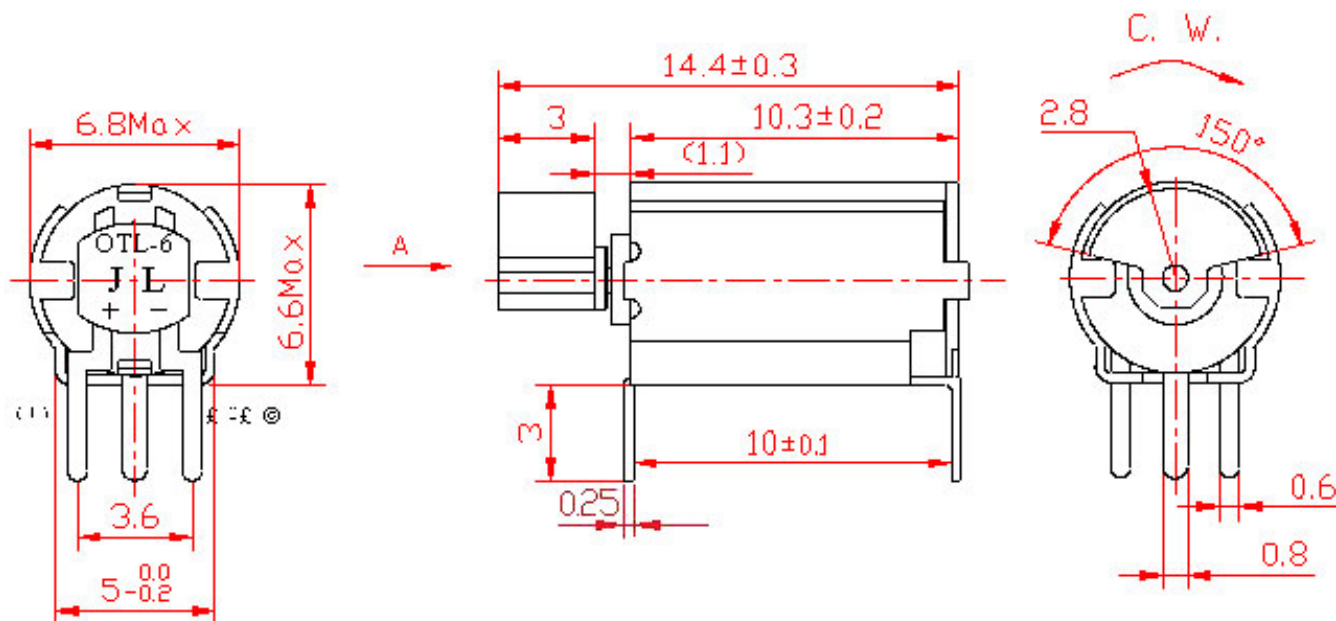

1. General scope

1-1 The specifications apply to the coreless cylindrical permanent magnetic micro vibration motor DC model **Z6S00A010F**.

2. Operating conditions

Items	Specifications	Condition & Remarks
2-1	Rated voltage	1.3V DC
2-2	Rated load	Counter weight
2-3	Rotation	C.W. (clockwise)
2-4	Motor position	All positions
2-5	Operating voltage	0.9 ~ 1.6V DC
2-6	Operating conditions	-30 ~ 70°C, ordinary humidity
2-7	Storage conditions	-40 ~ 80°C, ordinary humidity

3. Measuring conditions

Items		Specifications	Condition & Remarks
3-1	Temperature	20±2°C	
3-2	Humidity	(63 ~ 67%) RH	
3-3	Motor position	Motor shaft horizontal	Lock the motor in a test fixture.

3-4 All data are based on the measuring conditions: Temperature, 20°C; Humidity, 65% RH. If any disagreement occurs, such test conditions are available: Temperature, 5~35°C; Humidity, 45 ~ 85% RH.

4. Mechanical specifications

Items		Specifications	Condition & Remarks
4-1	Configuration	As specified in outline drawing	Outline drawing No: Z6SCAA0061141 old number - Z6S00A010F .
4-2	Appearance	There shall be no evidence of mechanical damage and shall not have inadequate corrosion, etc.	Visual examination: Inspection carried out on samples.
4-3	Shaft end play	0.1 ~ 0.3mm	
4-4	Weight of motor	2.52g approx.	Body + Vibration weight: 2.00+0.52.
4-5	Holding strength of vibration weight	49N (5kgf)	

5. Performance and characteristics

Items		Specifications	Condition & Remarks
5-1	Rated speed	8500±2000rpm	At rated voltage and rated load (vibration weight).
5-2	Rated current	80mA max	
5-3	Stall current	140mA max	At rated voltage.
5-4	Starting voltage	0.75V DC max	At rated load (vibration weight) any position of rotor.
5-5	Insulation resistance	1M• min	At DC 100V between the lead wires and motor body.
5-6	Terminal resistance	11• approx.	At 20°C.
	Mechanical noise	50db (A) max	

Measured at rated voltage and rated load (vibration weight).

Background noise: 28db (A) max. @ 10cm.

Measuring instruments: B & K.

The weight of jig: 700g.

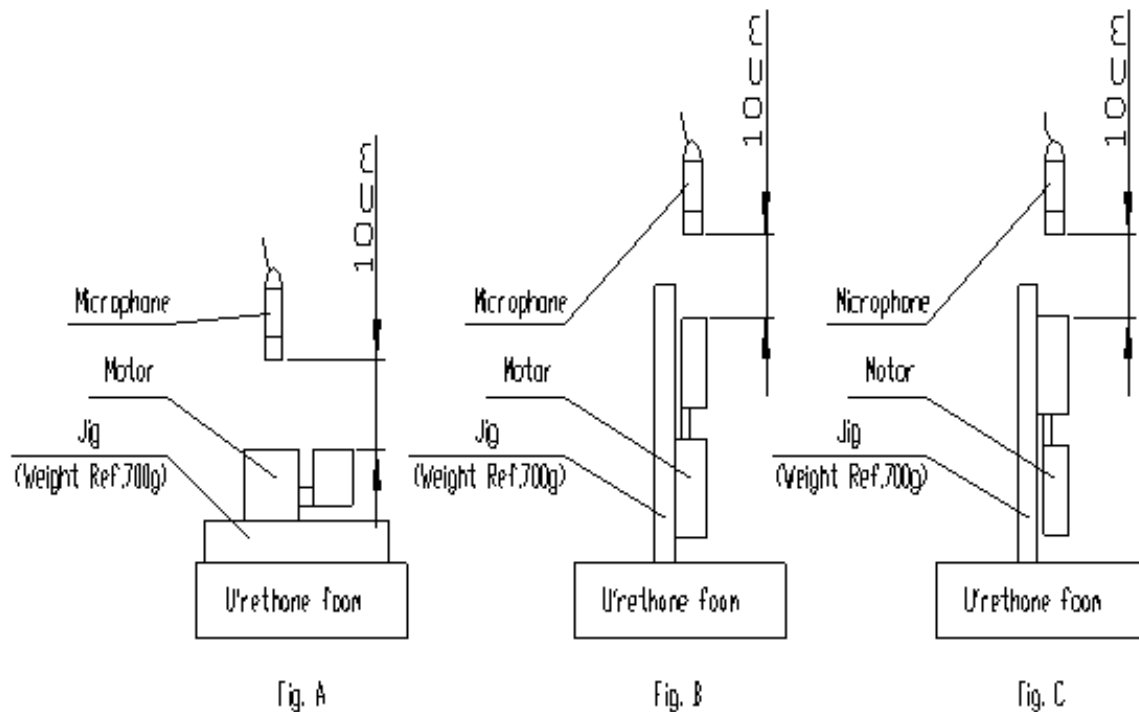

6. Reliability Test

Items		Standard test conditions		Condition & Remarks	
6-1	Life test			After 2 hours exposure in ordinary Motors shall be approved as specified in item 7-1.	
		Position	Horizontal		Horizontal
		Voltage	Rated		Rated
		Load	Vibe weight		Vibe weight
		Temperature	20°C		40°C
		Humidity	65%		90%
		Life (cycles)	200,000		400,000
6-2	Low temperature exposure test	Temperature: $-40 \pm 2^\circ\text{C}$ Time: 96hrs		After 2 hours exposure in ordinary Motors shall be approved as specified in item 7-2.	
6-3	High temperature exposure test	Temperature: $60 \pm 2^\circ\text{C}$ Time: 96hrs			
6-4	High humidity exposure test	Temperature: $40 \pm 2^\circ\text{C}$ Humidity: 90 ~ 95% RH Exposure time: 240hrs Dry time: 4hrs No condensation of moisture			

6-5	Vibration test	<p>Displacement: 1.5mm (p-p)</p> <p>Frequency: 10 ~ 55Hz</p> <p>Period: 20 Mins log sweep (10 ~ 55 ~ 10Hz)</p> <p>Direction: x, y, z</p> <p>Time: Every 2 hours</p>	After the test motors shall be approved as specified in item 7-2.
6-6	Drop test	<p>Set the motor to the approximately 100g (include the motor) weight of block drop the motor on the concrete floor.</p> <p>Height: 1.5 meters</p> <p>Direction: $\pm x, \pm y, \pm z$</p> <p>Times: Twice Each</p>	After the test motors shall be approved as specified in item 7-2.

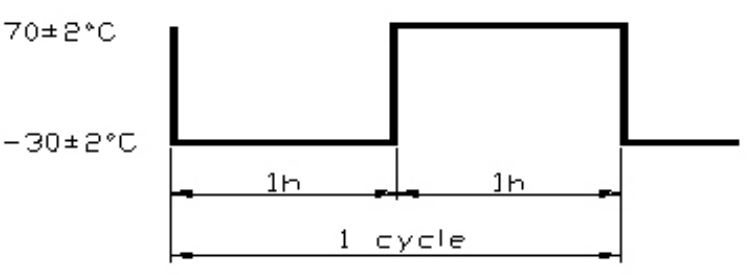
6-7	Heat stock test	 <p>70±2°C</p> <p>-30±2°C</p> <p>1h</p> <p>1h</p> <p>1 cycle</p> <p>Period: 32 cycles</p> <p>Exposed at ordinary temperature and ordinary humidity for 24 hours before measurement.</p>	After the test motors shall be approved as specified in item 7-2.
-----	-----------------	---	---

7. Post environmental

Items	Requirements
-------	--------------

7-1	Table A	<p>1) Rated speed: Initial data -30% min./ +60% max.</p> <p>2) Rated current: Initial data ± 30% max</p> <p>3) Insulation resistance: 1M• min</p> <p>4) Starting voltage: 1.1V DC max</p> <p>5) Current waveform: Normal</p>
7-2	Table B	<p>1) Rated speed: Initial data -30% min./ +60% max.</p> <p>2) Rated current: Initial data ± 30% max</p> <p>3) Starting voltage: 1.1V DC max</p>

8. Matters to be paid attention to when using motor

8-1 Lay the motors carefully in transportation to avoid any damage to the motor body or its electric function because of collision.

8-2 Storage temperature 20°C±10°C. Do not leave the motors in the environment of high temperature, high humidity and gas that will cause rust and corrosion. Please don't store the motors for over 6 months.

8-3 Do not lock the motor shaft when the electric power is supplied.

8-4 Do not touch the weights when motor is rotating.

[Home](#) | [Product Info](#) | [About us](#) | [Factory tour](#) | [ISO Certifications](#) | [RoHS Info](#) | [Sample Request](#) | [Contact us](#) | [Email us](#)

Copyright 2008 © VibratorMotor.com