



JinLong Machinery
VibratorMotor.com

KOTL

Home | Product Info | About us | Factory tour | ISO Certifications | RoHS Info | Sample Request | Contact us | Email us

Part No. Z4SL2B0280131 (Old Part Number : 4SL-2813B)

Download



PDF Format

Technical Requirements:

1. Rated voltage: 3.0V DC
2. Rated current: 62mA max.
3. Rated speed: 11000+/-2000rpm
4. Stall current: 80mA max.
5. Terminal resistance: 41ohms
6. Starting voltage: 1.7V max.
7. Shaft end play: 0.05~0.2mm
9. Material of lead wires: AWG32 UL1571

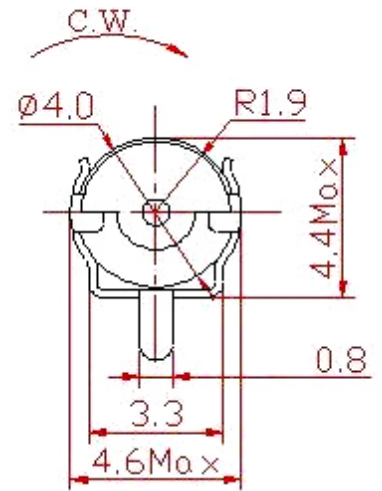
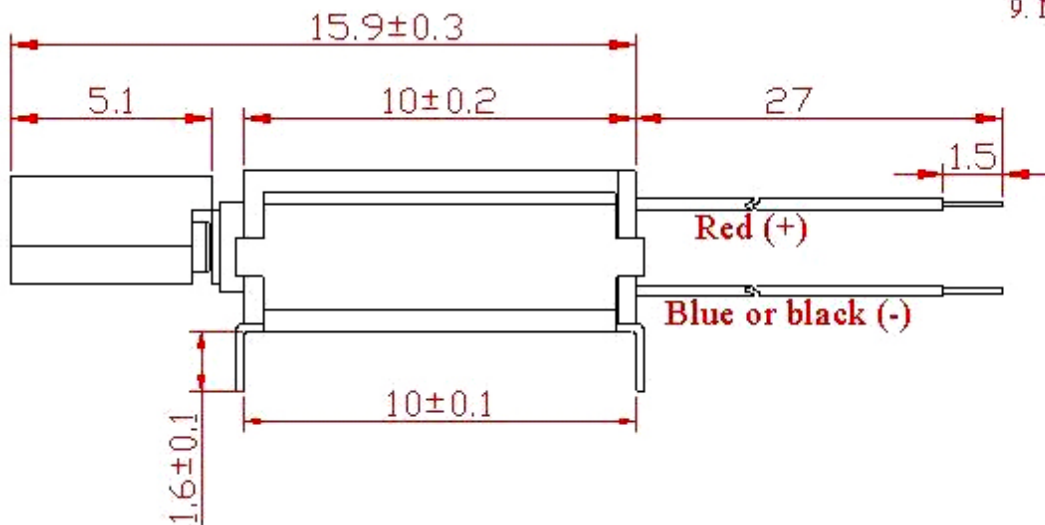

1. General scope

1-1 The specifications apply to the coreless cylindrical permanent magnetic micro vibration motor

DC model **Z4SL2B0280131**.

2. Operating conditions

Items	Specifications	Condition & Remarks
2-1	Rated voltage	3.0V DC
2-2	Rated load	Vibration weight As specified in the outline drawing.

2-3	Rated speed	11,000±2000rpm	
2-4	Rotation	C.W. (clockwise)	
2-5	Motor position	All positions	
2-6	Operating voltage	2.0~4.0V DC	
2-7	Operating conditions	-30 ~ 70°C, ordinary humidity	No condensation of moisture.
2-8	Storage conditions	-40 ~ 80°C, ordinary humidity	No condensation of moisture.

3. Measuring conditions

Items	Specifications	Condition & Remarks
3-1	Temperature	20±2°C
3-2	Humidity	(63 ~ 67%) RH
3-3	Motor position	Motor shaft horizontal Lock the motor in a test fixture.

3-4 All data are based on the measuring conditions: Temperature, 20°C; Humidity, 65% RH. If any disagreement occurs, such test conditions are available: Temperature, 5~35°C; Humidity, 45 ~ 85% RH.

4. Mechanical specifications

Items	Specifications	Condition & Remarks
4-1	Configuration	As specified in outline drawing Outline drawing No: Z4SL2B0280131 .
4-2	Appearance	There shall be no evidence of mechanical damage and shall not have inadequate corrosion, etc. Visual examination: Inspection carried out on samples.
4-3	Shaft end play	0.05 ~ 0.2mm
4-4	Weight of motor	1.24g approx. Body + Vibration weight: 0.73+0.51
4-5	Holding strength of vibration weight	49N (5kgf)

5. Performance and characteristics

Items	Specifications	Condition & Remarks
5-1	Rated speed	11,000±2000rpm At rated voltage and rated load (vibration weight).
5-2	Rated current	62mA max
5-3	Stall current	80mA max At rated voltage.
5-4	Starting voltage	1.7V DC max At rated load (vibration weight) any position of rotor.

5-5	Insulation resistance	1M• min	At DC 100V between the lead wires and motor body.
5-6	Terminal resistance	41• approx.	At 20°C.
	Mechanical noise	50db (A) max	

Measured at rated voltage and rated load (vibration weight).

Background noise: 28db (A) max. @ 10cm.

Measuring instruments: B & K.

The weight of jig: 700g.

5-7

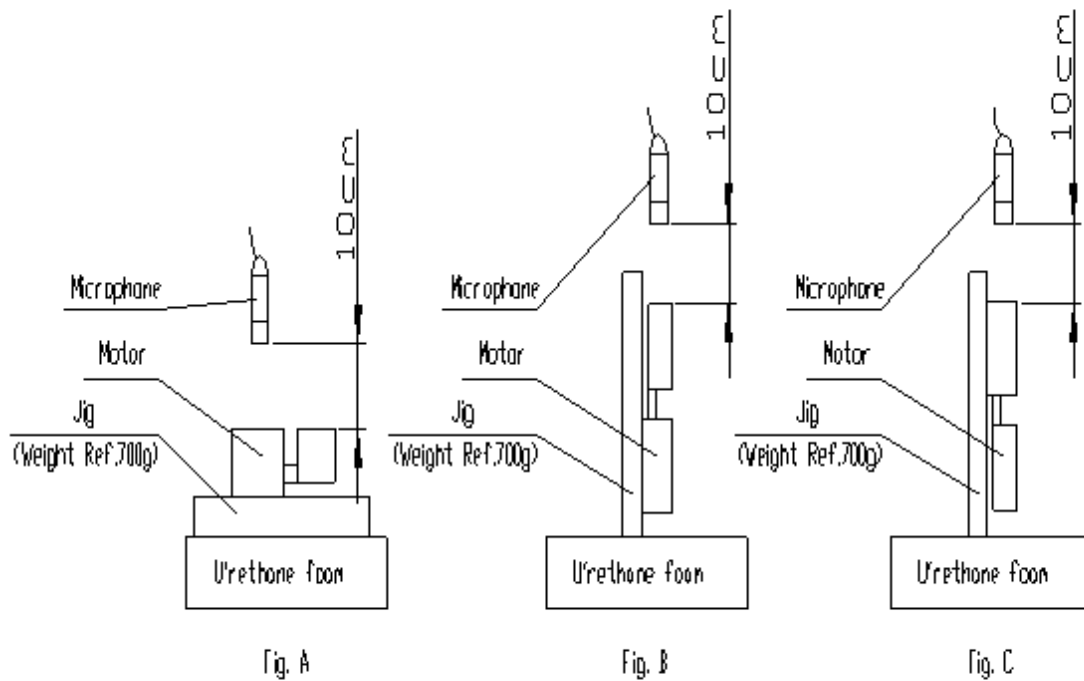

6. Reliability Test

Items	Standard test conditions	Condition & Remarks
-------	--------------------------	---------------------

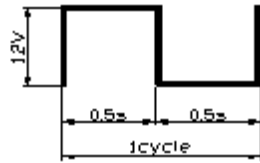

6-1 Life test

After 2 hours exposure in ordinary Motors shall be approved as specified in item 7-1.

Position	Horizontal	Horizontal
Voltage	Rated	Rated
Load	Vibe weight	Vibe weight
Temperature	20°C	40°C
Humidity	65%	90%
Life (cycles)	200,000	40,000

6-2 Low temperature exposure test

Temperature: -40±2°C
Time: 24hrs

6-3 High temperature exposure test

Temperature: 85±2°C
Time: 300hrs

6-4 High humidity exposure test

Temperature: 60±2°C
Humidity: 90 ~ 95% RH
Exposure time: 240hrs
Dry time: 4hrs
No condensation of moisture

After the test motors shall be approved as specified in item 7-2.

6-5 Vibration test

Displacement: 1.5mm (p-p)
Frequency: 10 to 55Hz
Period: 20 Mins log sweep (10 ~ 55 ~ 10Hz)
Direction: x, y, z
Time: Every 2 hours

After the test motors shall be approved as specified in item 7-2.

6-6 Drop test

Set the motor to the approximately 75g (include the motor) weight of block drop the motor on the concrete floor.
Height: 1.5 meters
Direction: ±x, ±y, ±z
Times: Every 2 hours

After the test motors shall be approved as specified in item 7-2.

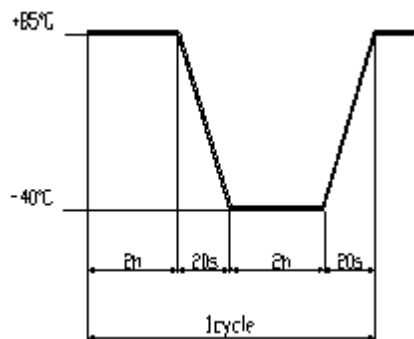

6-7 Heat stock test

After the test motors shall be approved as specified in item 7-2.

Period: 32 cycles

Exposed at ordinary temperature and ordinary humidity for 24 hours before measurement.

6-8 Sulfur gas

Temperature: 100°C
 Time: 48hrs
 Environment: Sulfur gas

No corrosion on the brush and the commutator.

6-9 Salt spray test

Temperature: 35°C
 Time: 48hrs
 Environment: 5% salt spray

No any sign of corrosion.

6-10 Las Vegas test

Temperature: 60°C
 Time: 48hrs
 Humidity: <20% RH
 Test mode: 8 secs on (C.W.)
 52 secs off

After the test motors shall be approved as specified in item 7-2.

7. Post environmental

Items	Requirements
-------	--------------

7-1	Table A	1) Rated speed:	Initial data -30% min./ +60% max.
		2) Rated current:	Initial data $\pm 30\%$ max
		3) Insulation resistance:	1M• min
		4) Starting voltage:	2.0V DC max
		5) Wave of current:	No blot wave.
7-2	Table B	1) Rated speed:	Initial data -30% min./ +60% max.
		2) Rated current:	Initial data $\pm 30\%$ max
		3) Starting voltage:	2.0V DC max

8. Caution and Matters

8-1 Warnings: In a motor near the end its life, or under breakdown conditions, short circuits can develop between commutator segments. Uncontrolled voltage may then leak into the power source circuit. Motors may overheat or fail if run continuously with its rotor locked condition or under excessive loads.

8-2 Destructive atmospheres: Do not use and store the motor in the corrosive gas atmosphere (H^2S , SO^2 , NO^2 , Cl^2 , etc.), or substances that can emit toxic gases, such as organic silicon, cyanide, formalin, or phenol compounds. The motor may get serious damages.

8-3 Condensation: Condensation on the electrical circuits can destroy the motor or control circuits. Monitor the environment and undertake measures to prevent condensation, such as installing condensation sensors to cut power when necessary.

8-4 Be aware of the following factors and perform necessary tests to check a motor's ability to adopt with your mechanism and applications: Motor life, electric noise, mechanical noise, vibration, static-electrical noise resistance, power-source noise resistance, drift of rpm, electrical resonance between control circuit and motor, mechanical resonance between subassembly and motor malfunction due to motor noise, electrical magnetic interference, malfunction due to magnetic flux leakage, destruction due to lightning-related power surge, grounding.

8-5 Some particular plastic materials can crack and fail after exposure to motor bearing oil. Perform test the motor in/on the subassembly to check the influence of the oiled plastic parts.

8-6 Avoid connecting a serial resistor to the motor if at all possible, as this can negatively affect reliability. If this is unavoidable, keep resistance as low as possible and test thoroughly for reliability before using.

8-7 When testing for UL, CSA or other safely standards, apply for approval for the entire subassembly.

8-8 Do not store motors under conditions of extreme temperatures or high humidity, or for longer than six months even room conditions. When removing out of packaging after storage, take precautions to prevent condensation.

8-9 Connections: Complete soldering operations within three seconds to prevent damage to leads and terminals. Make sure that the soldering tip does not exceed $350^{\circ}C$. Be gentle with terminals; dents or pressure on them can lock up the motor.

8-10 Please consults us in advance when design considerations call for forcefully stalling the motor using a short circuit at the terminal or reverse voltage. Such operations can shorten product life.

[Home](#) | [Product Info](#) | [About us](#) | [Factory tour](#) | [ISO Certifications](#) | [RoHS Info](#) | [Sample Request](#) | [Contact us](#) | [Email us](#)

Copyright 2008 © VibratorMotor.com