

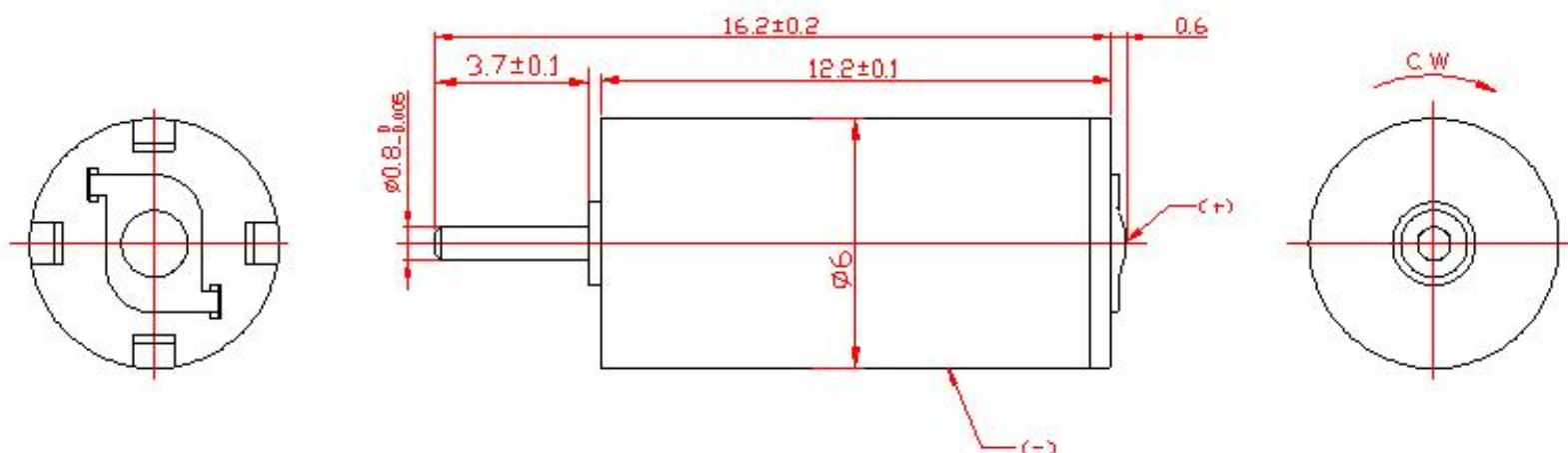

Part No. **Q6DH3**



1. General scope

1-1 The specifications apply to the coreless cylindrical permanent magnet motor DC model **Q6DH3 series**.

2. Operating conditions

Items	Specifications	Condition & Remarks
2-1 Rated voltage	See Item 8	
2-2 No load speed	See Item 8	
2-3 Direction of rotation	C.W. (clockwise)	
2-4 Motor posture	All positions	
2-5 Operating voltage	0.9 ~ 1.6V DC	
2-6 Operating conditions	-20 ~ 60°C, 10 ~ 90% RH	

2-7	Storage conditions	-40 ~ 80°C, 5 ~ 95% RH	No condensation of moisture.
-----	--------------------	------------------------	------------------------------

3. Measuring conditions

Items	Specifications	Condition & Remarks
3-1	Temperature	20±2°C
3-2	Humidity	(65±5%) RH
3-3	Motor posture	Motor shaft horizontal Lock the motor in a test fixture.

3-4 All data are based on the measuring conditions: 20°C, 65% RH. If any disagreement occurs, such test conditions are available: 5 ~ 35°C, 45 ~ 85% RH.

4. Mechanical specifications

Items	Specifications	Condition & Remarks
4-1	Configuration	As specified in outline drawing Outline drawing No: Q6DH3
4-2	Appearance	No evident mechanical damage and inadequate corrosion. Visual examination on samples.
4-3	Shaft end play	0.1 ~ 0.3mm
4-4	Weight of motor	1.30g approx.

5. Performance and characteristics

Items	Specifications	Condition & Remarks
-------	----------------	---------------------

5-1	No load speed	See Item 8	At rated voltage
5-2	No load current	See Item 8	At rated voltage
5-3	Stall current	See Item 8	At rated voltage
5-4	Starting voltage	See Item 8	
5-5	Terminal resistance	See Item 8	At 20°C
5-6	Mechanical noise	35db avg./ 50db (A) max	

6. Reliability Test

Items		Standard test conditions	Condition & Remarks
6-1	Life test	Voltage: 1.3V DC Temperature: $20\pm 2^{\circ}\text{C}$ Humidity: $65\pm 5\%$ RH Test mode 1: continuous run, 100 hours Test mode 2: 8s on/ 8s off, 20000 cycles	After 2 hours exposure in ordinary Motors shall be approved as specified in item 7-1.
6-2	Low temperature exposure test	Temperature: $-20\pm 2^{\circ}\text{C}$ Time: 96hrs	After 2 hours exposure in ordinary Motors shall be approved as specified in item 7-2.
6-3	High temperature exposure test	Temperature: $60\pm 2^{\circ}\text{C}$ Time: 96hrs	
6-4	High humidity exposure test	Temperature: $40\pm 2^{\circ}\text{C}$ Humidity: $90\pm 5\%$ RH Exposure time: 96hrs Dry time: 4hrs No condensation of moisture	

6-5 Drop test	<p>Set the motor to the approximately 75g (include the motor) weight of block drop the motor on the concrete floor.</p> <p>Height: 1.2 meters</p> <p>Direction: $\pm x, \pm y, \pm z$</p> <p>Times: Each 2 times</p>	After the test motors shall be approved as specified in item 7-2
---------------	---	--

7. Post environmental

Items	Requirements
7-1 Table A	<p>1) No load speed: Initial data -30% min./ +60% max.</p> <p>2) No load current: Initial data $\pm 30\%$ max</p> <p>3) Starting voltage: 0.9V DC max</p> <p>4) Wave of current: No blot wave.</p>
7-2 Table B	<p>1) No load speed: Initial data -30% min./ +60% max.</p> <p>2) No load current: Initial data $\pm 30\%$ max</p> <p>3) Starting voltage: 0.9V DC max</p>

8. Main specifications

Q6DH3 Series

Part Number	Color of Cover	Nominal Voltage	Starting Voltage	Current		Normal Speed	Starting Current	Armature Resistance
		V DC.	V DC.	Avg. (mA)	Max. (mA)			
Q6DH3-1.0A	blue	1.3	0.8	15	25	10000 \pm 3000	< 70	20.5
Q6DH3-1.4A	black	1.3	0.6	25	30	14000 \pm 3000	< 130	10.5
Q6DH3-1.6A	green	1.3	0.6	30	35	16000 \pm 3000	< 150	8.5
Q6DH3-1.9A	brown	1.3	0.6	32	45	19000 \pm 3000	< 190	6.0
Q6DH3-2.2A	rose	1.3	0.6	40	50	22000 \pm 3000	< 265	3.6
Q6DH3-2.4A	yellow	1.3	0.6	45	55	24000 \pm 3000	< 285	3.2

Q6DH3-2.6A	purple	1.3	0.6	45	60	26000±3000	< 305	3.0
Q6DH3-2.8A	pink	1.3	0.6	50	70	28000±3000	< 327	2.8
Q6DH3-3.1A	orange	1.3	0.6	60	80	31000±3000	< 350	2.3

Q6DH3-X Series

Part Number	Nominal Voltage	Starting Voltage	Current	Normal Speed	Stall Current	Armature Resistance
	V DC.	V DC.	mA	rpm	mA	$\Omega \pm 3\%$
Q6DH3-2.0AX	1.3	0.6 Max	50 Max	20,000±3000	320 Max	2.7
Q6DH3-2.7AX	1.3	0.6 Max	85 Max	27,000±3000	420 Max	1.63
Q6DH3-3.4AX	1.3	0.6 Max	110 Max	34,000±3000	540 Max	1.25

9. Cautions and matters

9-1 Warnings: In a motor near the end its life, or under breakdown conditions, short circuits can develop between commutator segments. Uncontrolled voltage may then leak into the power source circuit. Motors may overheat or fail if run continuously with its rotor locked condition or under excessive loads.

9-2 Destructive atmospheres: Do not use and store the motor in the corrosive gas atmosphere (H_2S , SO_2 , NO_2 , Cl_2 , etc.), or substances that can emit toxic gases, such as organic silicon, cyanide, formalin, or phenol compounds. The motor may get serious damages.

9-3 Condensation: Condensation on the electrical circuits can destroy the motor or control circuits. Monitor the environment and undertake measures to prevent condensation, such as installing condensation sensors to cut power when necessary.

9-4 Some particular plastic materials can crack and fail after exposure to motor bearing oil. Perform test the motor in/on the subassembly to check the influence of the oiled plastic parts.

9-5 Avoid connecting a serial resistor to the motor if at all possible, as this can negatively affect reliability. If this is unavoidable, keep resistance as low as possible and test thoroughly for reliability before using.

9-6 When testing for UL, CSA or other safely standards, apply for approval for the entire subassembly.

9-7 Do not store motors under conditions of extreme temperatures or high humidity, or for longer than six months even room conditions. When removing out of packaging after storage, take precautions to prevent condensation.

9-8 Please consults us in advance when design considerations call for forcefully stalling the motor using a short circuit at the terminal or reverse voltage. Such operations can shorten product life.

[Home](#) | [Product Info](#) | [About us](#) | [Factory tour](#) | [ISO Certifications](#) | [RoHS Info](#) | [Sample Request](#) | [Contact us](#) | [Email us](#)

Copyright 2008 © VibratorMotor.com