



JinLong Machinery
VibratorMotor.com

KOTL

Home | Product Info | About us | Factory tour | ISO Certifications | RoHS Info | Sample Request | Contact us | Email us

Part No. Z6SH1A0060711 (Old Part Number : 6SH1-0671A)

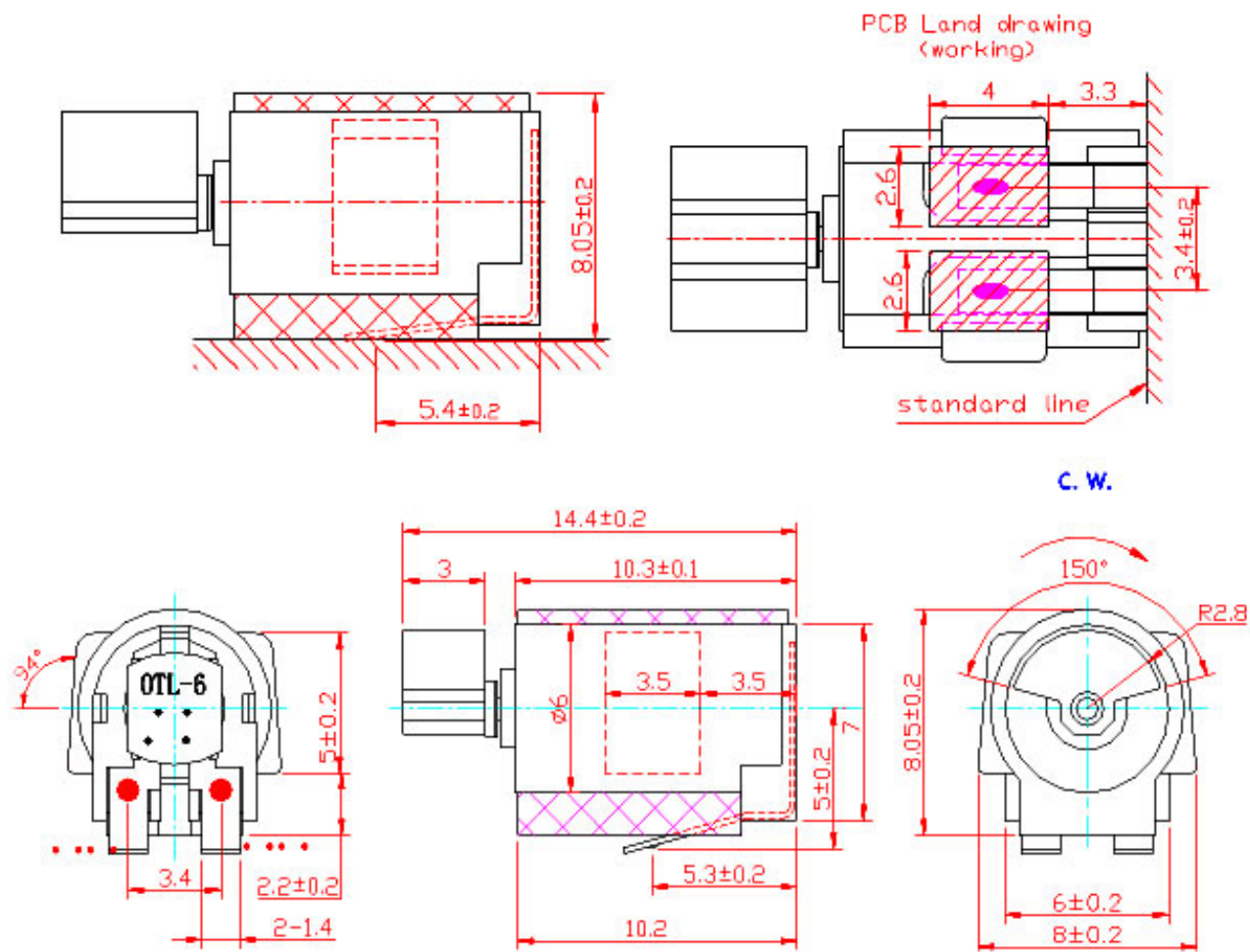

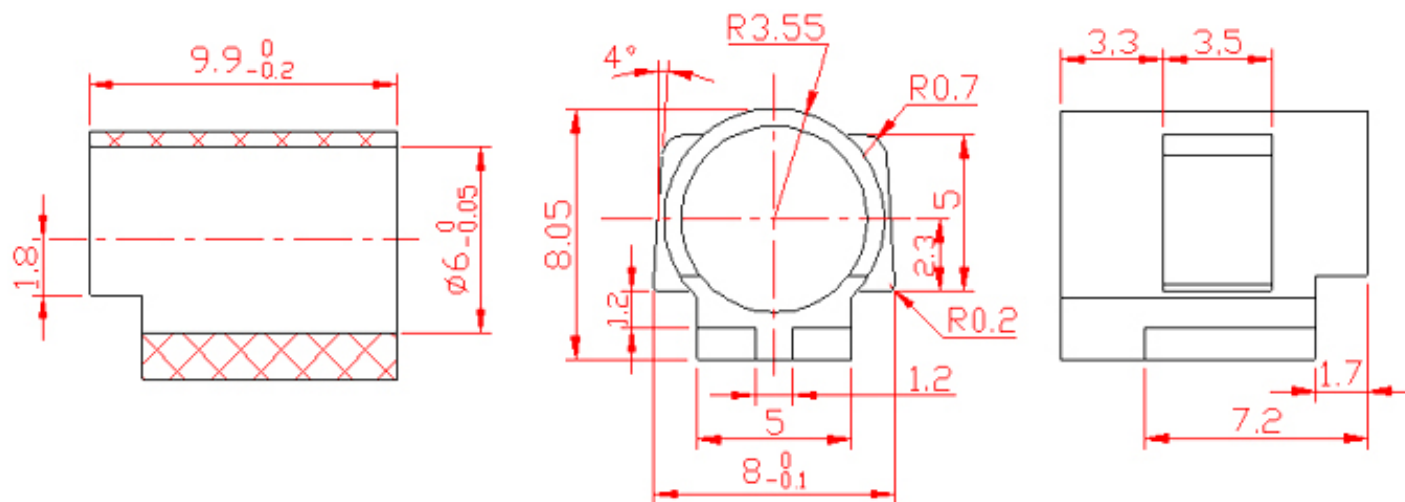

1. General scope

1-1 The specifications apply to the coreless cylindrical permanent magnetic micro vibration motor DC model

Z6SH1A0060711.

2. Operating conditions

Items	Specifications	Condition & Remarks	
2-1	Rated voltage	1.3V DC	
2-2	Rated load	Vibration weight	As specified in the outline drawing.
2-3	Rated speed	8000± 1500rpm	
2-4	Rotation	C.W. (clockwise)	
2-5	Motor position	All positions	
2-6	Operating voltage	0.9 ~ 1.6V DC	
2-7	Operating conditions	-30 ~ 70°C, ordinary humidity	No condensation of moisture.
2-8	Storage conditions	-40 ~ 80°C, ordinary humidity	No condensation of moisture.

3. Measuring conditions

Items	Specifications	Condition & Remarks	
3-1	Temperature	20± 2°C	
3-2	Humidity	(63 ~ 67%) RH	
3-3	Motor position	Motor shaft horizontal	Lock the motor in a test fixture.

3-4 All data are based on the measuring conditions: Temperature, 20°C; Humidity, 65% RH. If any disagreement occurs,

such test conditions are available: Temperature, 5~35°C; Humidity, 45 ~ 85% RH.

4. Mechanical specifications

Items		Specifications	Condition & Remarks
4-1	Configuration	As specified in outline drawing	Outline drawing No: Z6SH1A0060711 .
4-2	Appearance	There shall be no evidence of mechanical damage and shall not have inadequate corrosion, etc.	Visual examination: Inspection carried out on samples.
4-3	Shaft end play	0.1 ~ 0.3mm	
4-4	Weight of motor	2.52g approx.	Body + Vibration weight: 2.00+0.52.
4-5	Holding strength of vibration weight	49N (5kgf)	

5. Performance and characteristics

Items		Specifications	Condition & Remarks
5-1	Rated speed	8000± 1500rpm	At rated voltage and rated load (vibration weight).
5-2	Rated current	75mA max	
5-3	Stall current	125mA max	At rated voltage.
5-4	Starting voltage	0.75V DC max	At rated load (vibration weight) any position of rotor.
5-5	Insulation resistance	1M• min	At DC 100V between the lead wires and motor body.
5-6	Terminal resistance	11• approx.	At 20°C.
	Mechanical noise	50db (A) max	
<p>Measured at rated voltage and rated load (vibration weight).</p> <p>Background noise: 28db (A) max. @ 10cm.</p> <p>Measuring instruments: B & K.</p> <p>The weight of jig: 700g.</p>			

5-7

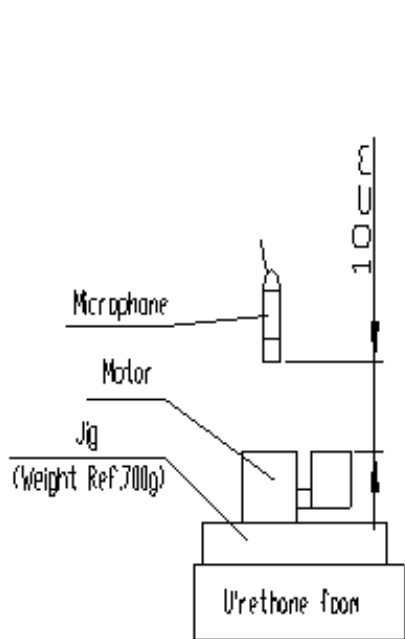

Fig. A

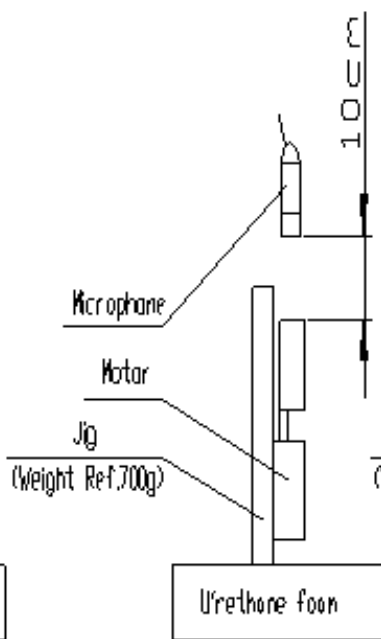

Fig. B

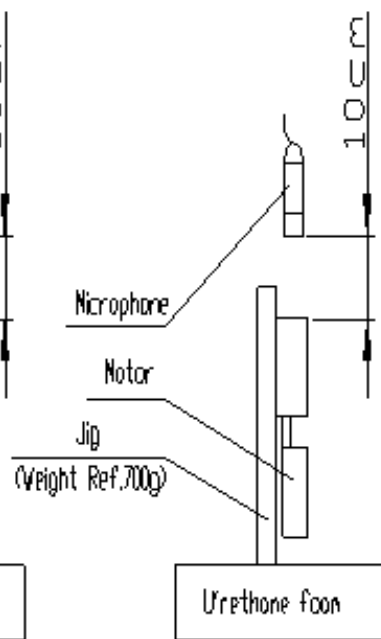
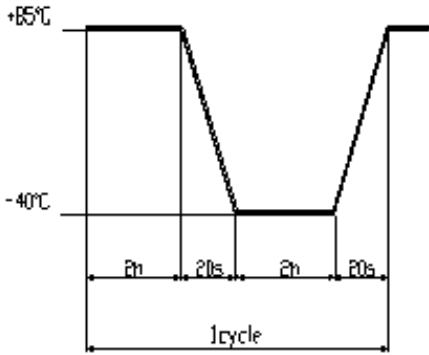

Fig. C

6. Reliability Test

Items		Standard test conditions			Condition & Remarks	
6-1	Life test					After 2 hours exposure in ordinary Motors shall be approved as specified in item 7-1.
		Position	Horizontal	Horizontal	1.	
		Voltage	Rated	Rated		
		Load	Vibe weight	Vibe weight		
		Temperature	20°C	40°C		
		Humidity	65%	90%		
		Life (cycles)	200,000	400,000		
6-2	Low temperature exposure test	Temperature: $-40 \pm 2^\circ\text{C}$ Time: 24hrs			After 2 hours exposure in ordinary Motors shall be approved as specified in item 7-2.	
6-3	High temperature exposure test	Temperature: $85 \pm 2^\circ\text{C}$ Time: 300hrs				
6-4	High humidity exposure test	Temperature: $60 \pm 2^\circ\text{C}$ Humidity: 90 ~ 95% RH Exposure time: 240hrs Dry time: 4hrs No condensation of moisture				

6-5	Vibration test	<p>Displacement: 1.5mm (p-p) Frequency: 10 ~ 55Hz Period: 20 Mins log sweep (10 ~ 55 ~ 10Hz) Direction: x, y, z Time: Every 2 hours</p>	<p>After the test motors shall be approved as specified in item 7-2.</p>
6-6	Drop test	<p>Set the motor to the approximately 100g (include the motor) weight of block drop the motor on the concrete floor. Height: 1.5 meters Direction: $\pm x, \pm y, \pm z$ Times: Each 2 times</p>	<p>After the test motors shall be approved as specified in item 7-2.</p>

6-7	Heat stock test		<p>After the test motors shall be approved as specified in item 7-2.</p>
		<p>Period: 32 cycles</p>	

		Exposed at ordinary temperature and ordinary humidity for 24 hours before measurement.	
6-8	Sulfur gas	Temperature: 100°C Time: 48hrs Environment: Sulfur gas	No corrosion on the brush and the commutator.
6-9	Salt spray test	Temperature: 35°C Time: 48hrs Environment: 5% salt spray	No any sign of corrosion.
6-10	Las Vegas test	Temperature: 60°C Time: 48hrs Humidity: <20% RH Test mode: 8 secs on (C.W.) 52 secs off	After the test motors shall be approved as specified in item 7-2.

7. Post environmental

Items		Requirements
7-1	Table A	1) Rated speed: Initial data -30% min./ +60% max. 2) Rated current: Initial data ±30% max 3) Insulation resistance: 1M• min 4) Starting voltage: 1.1V DC max 5) Wave of current: No blot wave.
7-2	Table B	1) Rated speed: Initial data -30% min./ +60% max. 2) Rated current: Initial data ±30% max 3) Starting voltage: 1.1V DC max

8. Caution and Matters

8-1 Warnings: In a motor near the end its life, or under breakdown conditions, short circuits can develop between commutator segments. Uncontrolled voltage may then leak into the power source circuit. Motors may overheat or fail if run continuously with its rotor locked condition or under excessive loads.

8-2 Destructive atmospheres: Do not use and store the motor in the corrosive gas atmosphere (H₂S, SO₂, NO₂, Cl₂, etc.), or substances that can emit toxic gases, such as organic silicon, cyanide, formalin, or phenol compounds. The motor may get serious damages.

8-3 Condensation: Condensation on the electrical circuits can destroy the motor or control circuits. Monitor the environment and undertake measures to prevent condensation, such as installing condensation sensors to cut power when necessary.

8-4 Be aware of the following factors and perform necessary tests to check a motor's ability to adopt with your mechanism and applications: Motor life, electric noise, mechanical noise, vibration, static-electrical noise resistance, power-source noise resistance, drift of rpm, electrical resonance between control circuit and motor, mechanical resonance between subassembly and motor malfunction due to motor noise, electrical magnetic interference, malfunction due to magnetic flux leakage, destruction due to lightning-related power surge, grounding.

8-5 Some particular plastic materials can crack and fail after exposure to motor bearing oil. Perform test the motor in/on the subassembly to check the influence of the oiled plastic parts.

8-6 Avoid connecting a serial resistor to the motor if at all possible, as this can negatively affect reliability. If this is unavoidable, keep resistance as low as possible and test thoroughly for reliability before using.

8-7 When testing for UL, CSA or other safely standards, apply for approval for the entire subassembly.

8-8 Do not store motors under conditions of extreme temperatures or high humidity, or for longer than six months even room conditions. When removing out of packaging after storage, take precautions to prevent condensation.

8-9 Connections: Complete soldering operations within three seconds to prevent damage to leads and terminals. Make sure that the soldering tip does not exceed 350°C. Be gentle with terminals; dents or pressure on them can lock up the motor.

8-10 Please consults us in advance when design considerations call for forcefully stalling the motor using a short circuit at the terminal or reverse voltage. Such operations can shorten product life.

[Home](#) | [Product Info](#) | [About us](#) | [Factory tour](#) | [ISO Certifications](#) | [RoHS Info](#) | [Sample Request](#) | [Contact us](#) | [Email us](#)

Copyright 2008 © VibratorMotor.com