

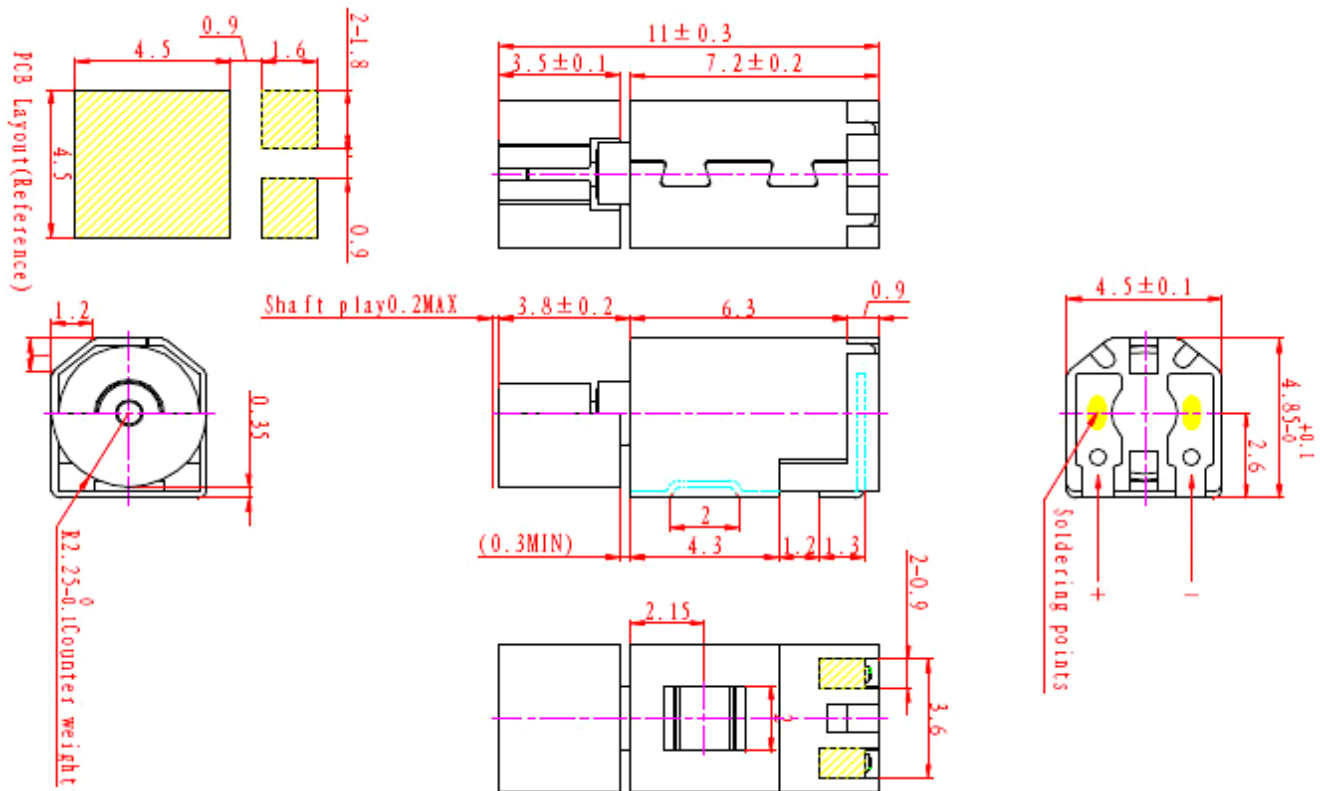

Part No. **4FC1B1301781**

SURFACE MOUNT - REFLOW SOLDERABLE



1. General scope

1-1 The specifications apply to the coreless cylindrical permanent magnetic micro vibration motor

DC model **Z4FC1B1301781**.

1. Standard Condition

1-1 Standard Voltage	3.0V DC
1-2 Voltage Range	2.6~3.6V DC
1-3 Standard Load	Counter weight R2.25x3.5L
1-4 Rotating Direction	C.W. from the directing of the Counter weight
1-5 Moving temp. range	-10°C~+60°C
1-6 Storage temp. range	-40°C~+85°C (temp. 20°C, relative humidity 65% RH, pressure 1013hPa)
1-7 Motor position	All direction

2. Measuring Condition

- 2-1 Motor position Horizontal
- 2-2 Current DC stabilized current
- 2-3 Temp/Humidity Principle measurement 5•C~35•C, relative humidity 30%~90%. For abnormalities, 20•C±2•C, 65%±5% RH
- 2-4 Rotating direction C.W. from the direction of the counter weight (CW)

3. Electrical Features

- 3-1 Standard loaded rotation **10000±2500** rpm (under Standard Voltage and load)
- 3-2 Standard loaded current **110 mA Max** (under Standard Voltage and load)
- 3-3 Starting current **130 mA Max** (under Standard Voltage)
(Locked current) (2/3R extreme resisting rate)
Not in the position which the brushes contact the commutator at two points
- 3-4 Standard loaded Starting Voltage Under loaded condition towards CW, rotor shall move in all positions at **2.6V**
(counter weight is turned 360° slowly)
- 3-5 Insulation resistance Under 50VDC, 1MΩ Min between motor terminal and case
- 3-6 Voltage Insulation Under 50V AC, without irregularities in 1 min between terminal and case
- 3-7 Electrical noise Using ring varistor
- 3-8 Wiring resistance 2/3 between poles **26.0Ω±3.0Ω**
- 3-9 Mechanical noise 50dB(A) max from 10cm
Background noise: 28dB(A) max

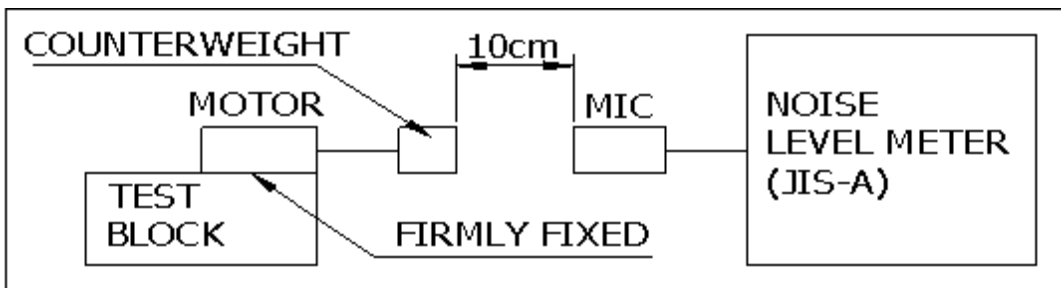

4. Mechanical Structure

- 4-1 Appearance External measurement which should be within the difference accordance ,Should not show Scratches, damages or loosening of the grip
- 4-2 End play of shaft 0.30mm or less
- 4-3 Weight **Approximately 1.2g**
- 4-4 Weight of counter weight **Approximately 0.6g**

5. Environment specification

- 5-1 Vibration Test Under packaged condition and vibration range of 1.5mm cycle, subjecting to continuous speed change of 2mm or more during 3mins or less.
Should satisfy item 3 & 4 even in additional of 30 mins with vibration of 1200~3300times/min.
- 5-2 Shock Test Inserting motor into a 6 sides simulated box (appx 60g), drop from 1.2m high on a concrete & metal surfaces and satisfying item 3 & 4
Drop times: two drops per plane for a total of 12 drops
- 5-3 Storage Test Temperature cycle (without presence of condensation on the motor)

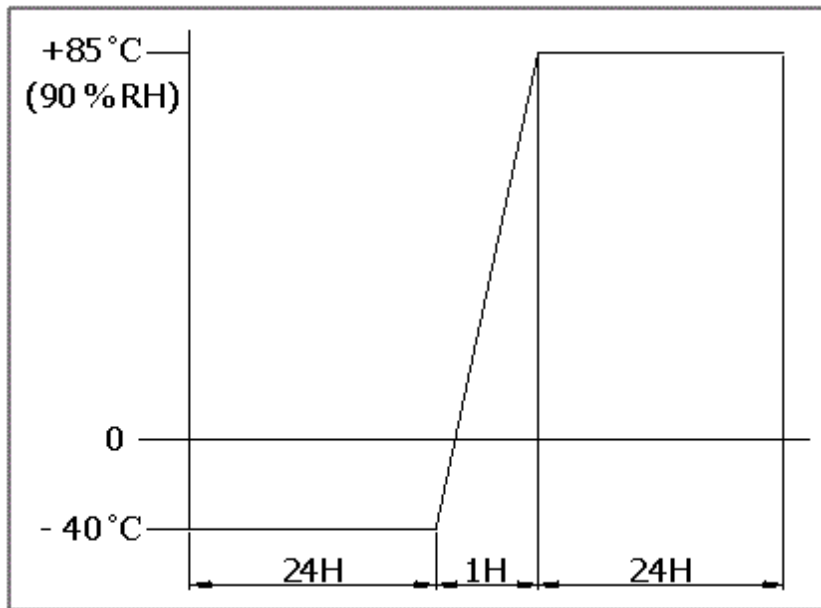

After exposure for 24Hrs and satisfy item 3 and 4

5-4 Counter weight High Temperature Test

No vividly remarkable corrosion at 60°C 90% HR after 250Hrs

5-5 Pull Test

Counter weight pull (Under normal temperature and humidity)
Counter weight must withstand axial pull of 3 kgf to destruct.

6. Life Test

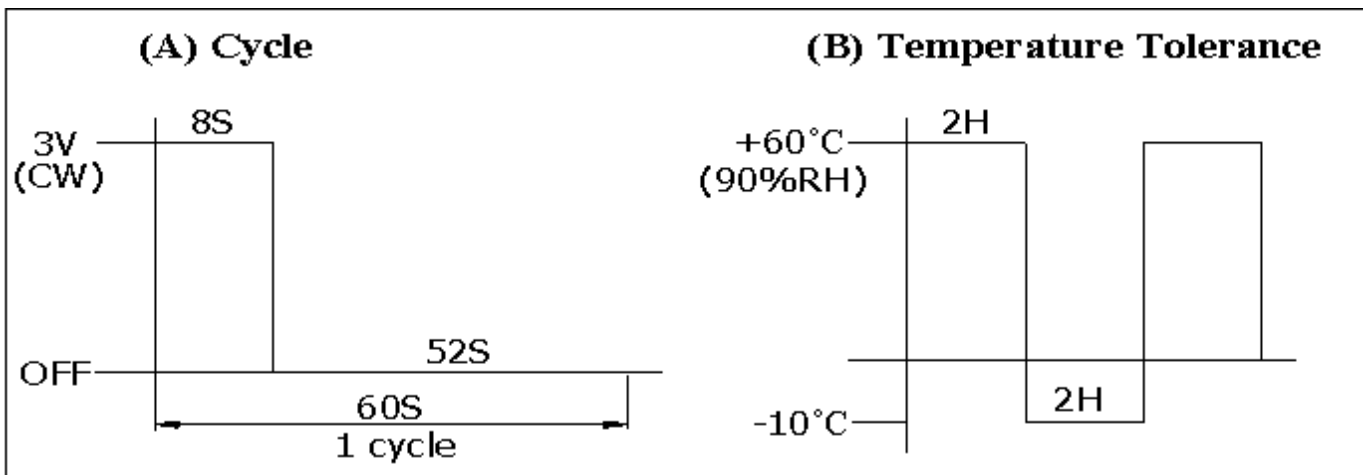

Input voltage: 3.0V DC

Counter weight: R2.25x3.5L appx 0.6g

(C) High temperature exposure at 60°C, 20% RH

(D) Standard verification

- (1) Variety rate of standard rotation is less than +30%/-20% from initial.
- (2) Variety rate of standard current is less than +20%/-30% form initial.

6-1 Temperature Shock Life Test

(B)To maintain (A) cycle for 140hrs in the process of temperature shock

(D)To satisfy the standard specification

6-2 High Temperature Exposure Life Test

(C)To maintain (A) cycle under high temperature for 48hrs

(D) To satisfy the standard specification

7. Packing Condition

7-1 Smallest packing condition

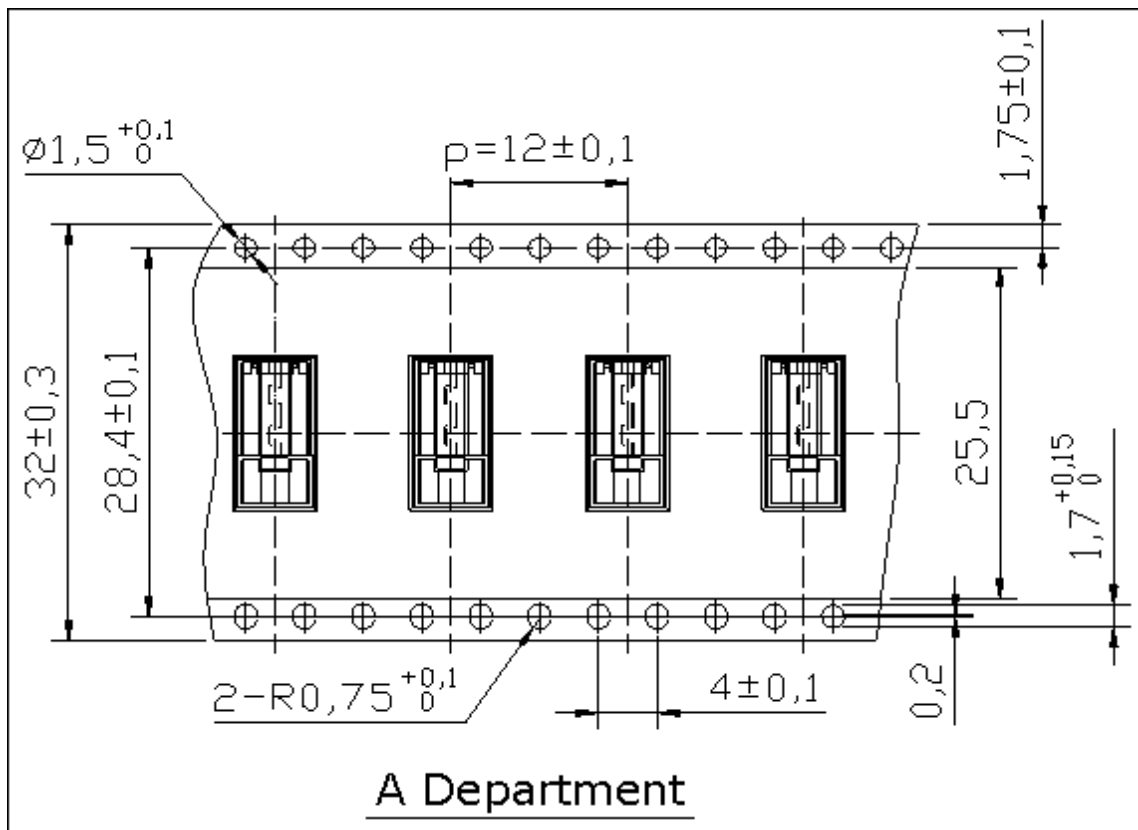

7-2 Cardboard Packing Condition

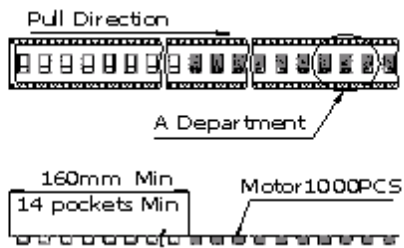
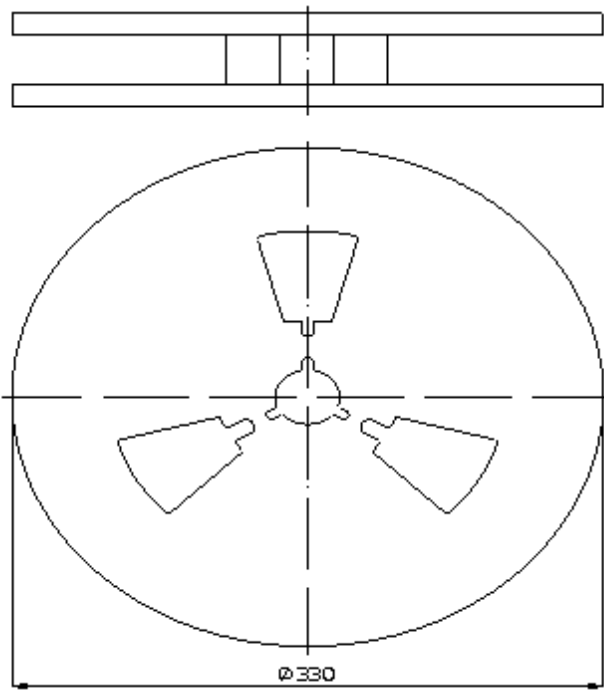

End part

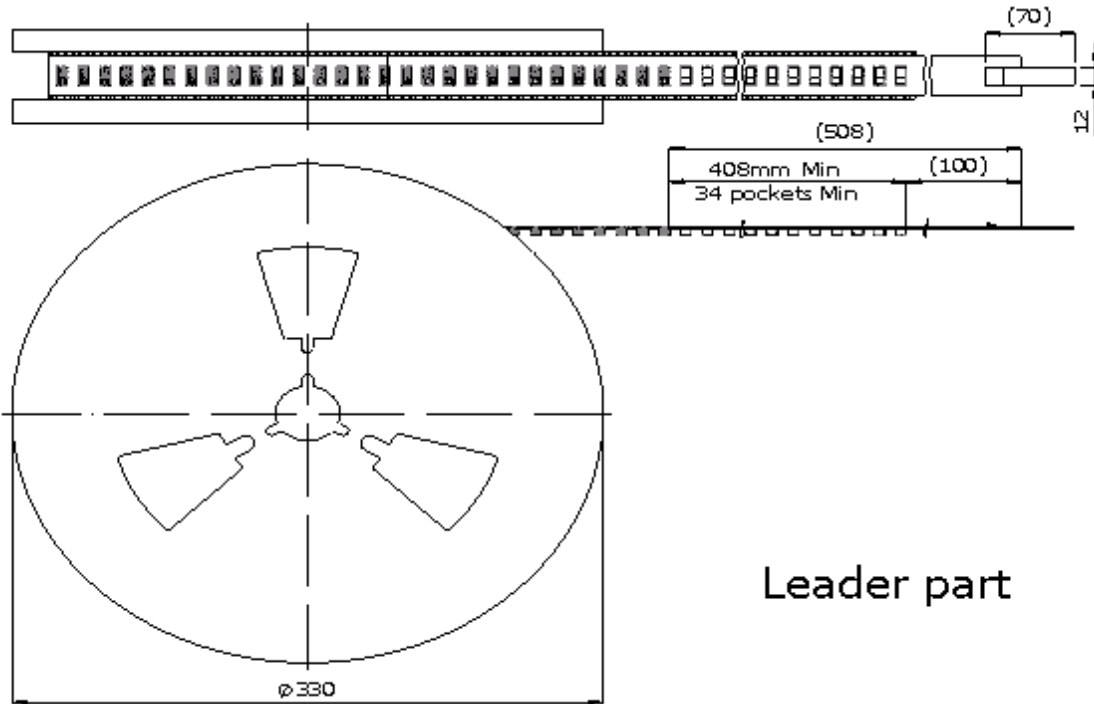

Leader part

7-3 Final Packing Condition

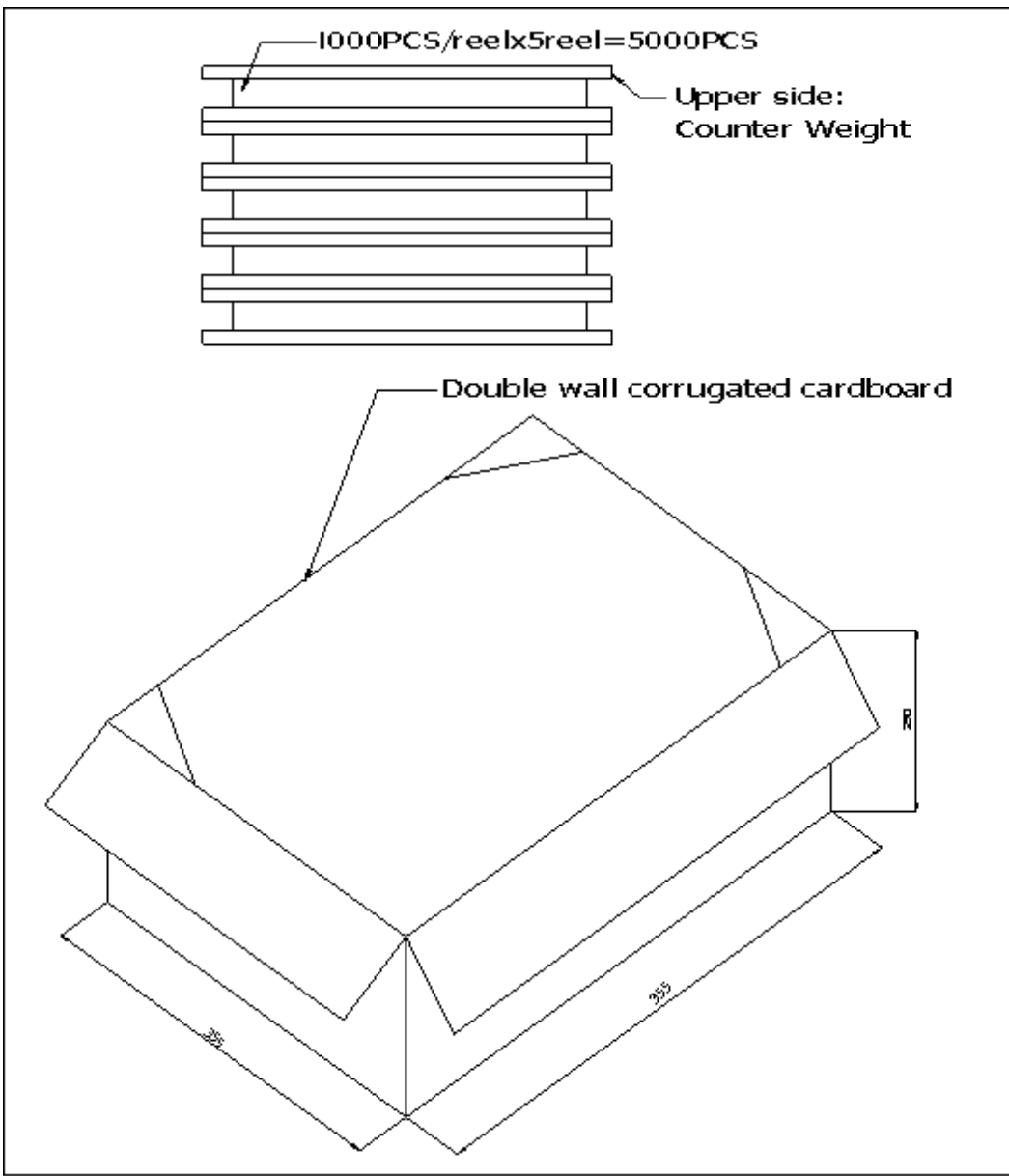

8. Others

8-1 Whatever items which be not stated in this specification will be not guaranteed.

8-2 Do not subject the motor under locked condition for long times.

8-3 Reflow Temperature : 250•CMax

Exceeding this temperature will result in shorting and dead spot failures.
Excessive heat weakens the magnets and it is also possible that the coating on the magnet wires melts causing a short in the motor.

8-4 Output test date and Cpk will be attached (n-35) of follows:

Loaded rotation	rpm
Loaded current	mA
Lock current (Starting Current)	mA
Starting voltage V (without consideration of Cpk value)	